



SOLVOX® Click Hose Kit. Standardized Quick-attach System for Diffuser Hoses.



SOLVOX® aquaculture diffuser hoses

Challenge Emergency oxygenation has been a standard safety feature in most fish farming tanks for decades. It is typically implemented by stretching diffuser hoses horizontally across the base of the fish tank. Attachment systems for diffuser hoses are often custom made and limited to one specific type of substrate. Custom made solutions do not always meet the standards that should apply for proper function and fish welfare. In addition, random diffuser designs have been known to compromise self-cleaning hydraulics in the tank. As a result, existing solutions often involve a lot of maintenance effort and are costly to repair or replace.

Solution Linde has developed the SOLVOX® click hose kit to meet this challenge. It is a quick-connect attachment system for diffuser hoses. The smooth surface finish minimizes the risk of fish getting injured or trapped. Designed for fast, easy installation, it is a flexible solution that works with conical and angled tank bases and is suited to a wide range of surfaces, materials and mounting options. In addition, it is robust in the presence of saline water, high levels of dissolved oxygen, UV light, strong chemical disinfection and detergent agents, and ozone.

Highlights

- Ease of installation and maintenance
- No sharp edges for greater fish safety
- Smooth surface finish for minimal bacterial growth
- Minimal possibility for hydrogen sulfide (H₂S) to develop
- Minimal chance of corrosion

Components SOLVOX® click hose kit is made up of a plastic hose holder, hose clamps, a sealant plate and an interface plate. The system can be assembled quickly and easily with few tools required, eliminating the need for tie wraps, tape or similar. The diffuser hose is simply clicked into the hose clamp, which sits on the horizontal support profile. All components can be easily replaced if required.

Compatibility SOLVOX click hose kit is designed as a standardized solution to fasten the SOLVOX aquaculture hose. Different mounting options (expansion/glued bolts in concrete plus plastic/welded adapters) allow the kit to be attached to different surface materials.

Surface material mounting options

	SOLVOX® Click hose holder – bolted version	SOLVOX® Click hose holder with interface plate – glued version
Glass fiber		●
Polyethylene (PE)		●
Concrete with glass fiber linde	●	●
Concrete with PE linde	●	●
Concrete	●	●

Physical dimensions in mm

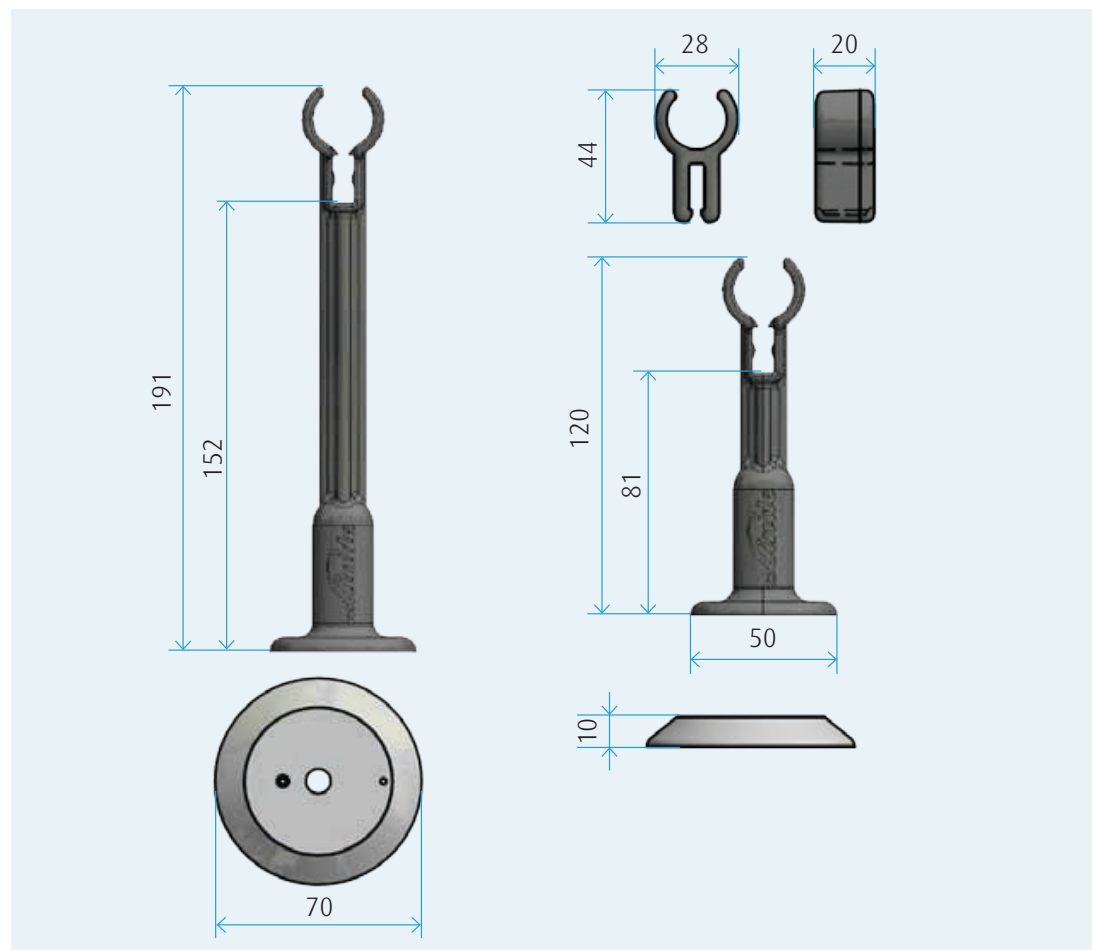

The SOLVOX® click hose kit comes with hose holders (choice of 2 heights available), an interface plate and sealant plate (not shown) for different surface mountings and greater flexibility.

Linde
 10 Riverview Drive
 Danbury CT 06810
 Phone 1.844.44LINDE (1.844.445.4633), Fax 1.800.772.9985; 716.879.2040
 www.linde.com

The Linde logo, the Linde wordmark and SOLVOX are trademarks or registered trademarks of Linde plc or its affiliates. The information contained herein is offered for use by technically qualified personnel at their discretion and risk without warranty of any kind.
 Copyright © 2023, Linde plc. 3/2023 P-40-5053