

## Product Safety Assessment

### Gaseous Argon

#### General

Argon is colorless, odorless and tasteless. It is known as one of the “Nobel” gases since it does not react with other materials. It is nonflammable, will not support combustion and is not life-supporting. The gas is heavier than air and is only slightly soluble in water. When liquid argon is vaporized and then heated it consumes a large amount of heat, making it an ideal coolant.

Argon is present in the atmosphere at a concentration of ~1%. Argon is recovered from air in an Air Separation Unit (ASU) where it is drawn off as a cryogenic liquid at about -308°F. Argon can then be distributed as a cryogenic liquid or as a gas in cylinders.

#### Applications

Argon has many commercial and technical applications. Argon inert properties are used as shielding/blanket gas for many metal process applications to prevent oxidation. Argon gas is used in lighting as an inert gas to promote life of lights and as an insulating gas for windows. Argon is used in many industries as a purging gas to remove impurities and contaminants like oxygen, nitrogen or water.

#### Health Effects

Argon is odorless, colorless, tasteless, and nonirritating, which means it has no warning properties. Humans possess no senses that can detect the presence of Argon.

Contact with rapidly expanding argon near the point of release may cause frostbite, with redness, skin color change to gray or white, and blistering.

No adverse ingestion effects are anticipated, but argon is a simple asphyxiant. Effects of oxygen deficiency resulting from simple asphyxiation may include rapid breathing, diminished mental alertness, impaired muscular coordination, faulty judgment, depression of all sensations, emotional instability, and fatigue. As asphyxiation progresses, nausea, vomiting, prostration, and loss of consciousness may result, eventually leading to convulsions, coma, and death.

At low oxygen concentrations, unconsciousness and death may occur in seconds and without warning.

Oxygen deficiency during pregnancy has produced developmental abnormalities in humans and experimental animals.

First aid measures are not required for gas. If frostbite is suspected, flush eyes with cool water for 15 minutes and obtain immediate medical attention. For frostbite, immerse skin in lukewarm water. DO NOT USE HOT WATER. Obtain medical attention.

Ingestion is unlikely since argon is a gas at room temperature. In cases of inhalation and overexposure, prompt medical attention is required. Rescue personnel should be equipped with self-contained breathing apparatus. Victims should be assisted to an uncontaminated area and inhale fresh air. Quick removal from the contaminated area is most important. Unconscious persons should be moved to an uncontaminated area, and if breathing has stopped, administer artificial resuscitation and supplemental oxygen. Further treatment should be symptomatic and supportive.

**Table 1 Gaseous Argon Physical and Chemical Properties**

Chemical Formula	Ar
Molecular Weight	40
Boiling Point (BP) @ 1 atm	-302.6°F (-189.9°C)
Freezing Point @ 1 atm	-308.9°F (-189.4°C)
Critical Temperature	-188°F (-85°C)
Critical Pressure	705.8 psia (48 atm)
Density, Liquid, @ BP, 1 atm	87.4 lb/scf
Density, Gas @ 68°F (20°C), 1 atm	0.103 lb/scf
Specific Gravity, Liquid (water=1) @ 68°F (20°C), 1 atm	1.40
Specific Volume @ 68°F (20°C), 1 atm	9.68 scf/lb
Latent Heat of Vaporization	2,804 Btu/lb mole
Expansion Ratio, Liquid to Gas, BP to 68°F (20°C)	1 to 840

**Containers**

Gaseous argon is shipped and stored in high-pressure cylinders, tubes, or tube trailers, which are designed and manufactured according to applicable codes and specifications for the pressures and temperatures involved. These vessels are manufactured according to Department of Transportation (DOT) regulations, which specify the material of construction, method of manufacture, testing, and with what products they are permitted to be filled, as well as other details. The quantity of product a container can hold is determined by its pressure rating and internal volume.

Permanent gaseous storage vessels are constructed to ASME codes, which specify the material of construction, method of manufacture, testing, and with what products they are permitted to be filled, as well as other details.

Cylinders

The most commonly used high-pressure cylinders are designed to hold gases at pressures up to 2200 psig; some ultra-high pressure commercial cylinders will contain gas at pressures up to 6000 psig.

High-pressure cylinders come in a variety of pressure ratings and capacities. The most commonly used cylinders for oxygen, nitrogen, argon, and helium are rated at 2200 psig. Other commonly used cylinders are 2485 psig and 2640 psig cylinders.

The common 2200 psig, argon cylinder weighs about 150 lb, depending on the grade of steel used in the cylinder body. Each cylinder has a valve on top and a steel cap that screws over the valve to protect it from damage. Each valve has a safety device designed to release pressure if the cylinder pressure becomes too high.

If the valve of a high-pressure gas cylinder is broken off, the contents of the cylinder may jet from a hole about 1/4" in diameter. The escaping gas could have enough thrust to turn the cylinder into a rocket, depending on the cylinder's size and weight.

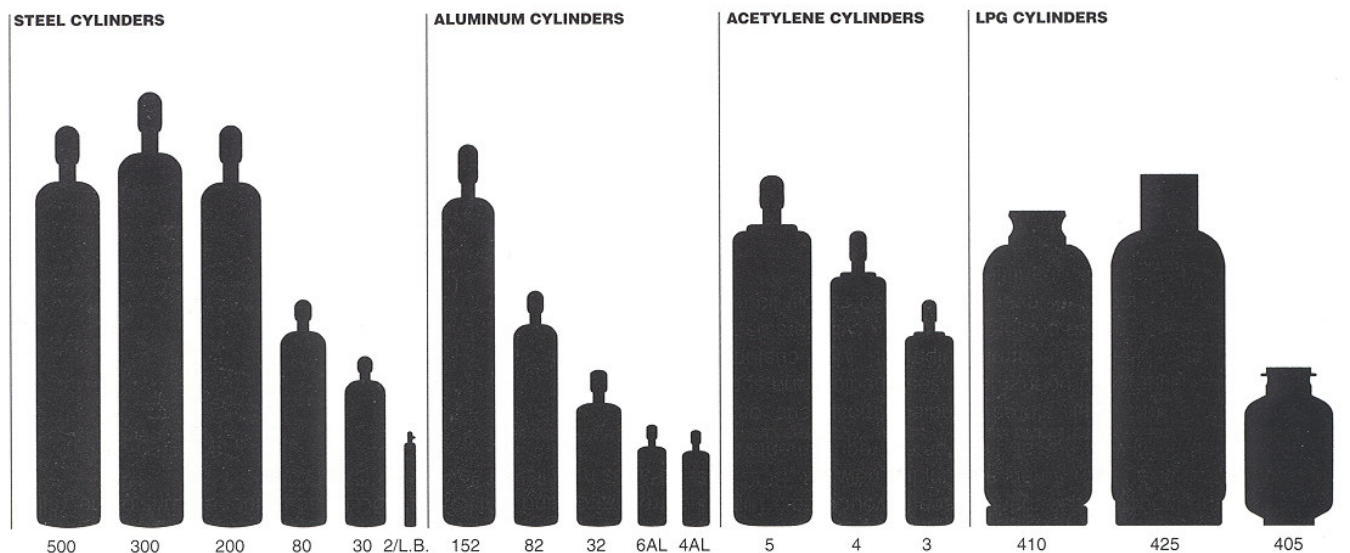

## Tubes

A tube is a pipe tapered at both ends. Each end is threaded to allow the installation of valves, connections, or relief devices.

Tubes for transportation are manufactured according to DOT regulations. Tubes manufactured for permanent storage are made to ASME codes. Tubes are generally mounted on a truck-trailer chassis or railcar bed, or placed at stationary locations when large amounts of oxygen are needed.

## **Valve Connections**

The Compressed Gas Association (CGA) recommends different connections for argon, depending on the pressure rating of the container, or type of service industry, such as medical or semiconductor. The following table shows these different connections (for detailed drawings of these connections, consult CGA Pamphlet V-1).

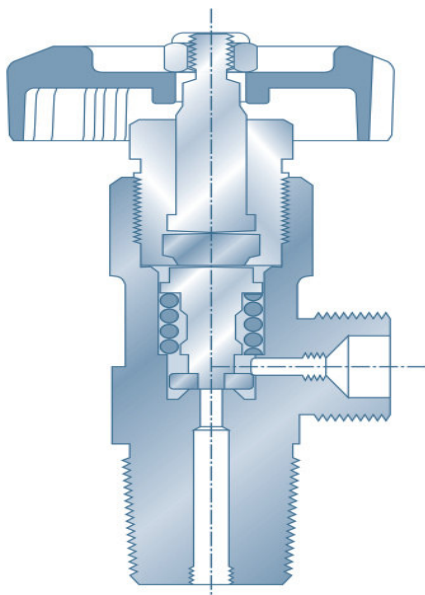

**Table**            **Argon Service Connections**

<u>Cylinder Service</u>	<u>CGA Connection</u>
Argon < 3,000 psig	580
Argon at 3,001 to 5,500 psig	680
Argon at 5,501 to 7,500 psig	677
Semiconductor	718

**WARNING: Do NOT use adapters to make cylinder connections!**

## **Pressure-Relief Devices**

Argon containers are equipped with pressure-relief devices to protect from over pressurization and possible rupture. Cylinders less than 65" long use a rupture disk device. Cylinders over 65" use a combination device consisting of a rupture disk backed by a fusible alloy. Combination devices require that both the temperature and pressure requirements be reached before the device will relieve.

For ASME tubes, pressure relief valves are also used to protect from over-pressurization.

## Container Stampings

Each cylinder or tube is identified by stampings in the metal of the shoulder. These markings refer to its service pressure rating, date of manufacture, and testing.



### Key to Cylinder Stampings

#### 1. Cylinder Specification

- DOT—Department of Transportation, which is the regulatory body that governs the use of cylinders.
- Specification of the cylinder type of material of construction (e.g., 3AA).
- Service or working pressure in pounds per square inch (e.g., 2,015 psi).

#### 2. Cylinder Serial Number

#### 3. Registered Owner Symbol

- Symbol used to indicate the original owner of the cylinders.
- ARCO or AGA is a Registered Owner Symbol for Linde.

#### 4. Date of Manufacture

- This date (month-year) also indicates the original hydrostatic test.

#### 5. Neck Ring Identification

- The cylinder neck ring displays the name of the current owner of the cylinder.

#### 6. Retest Markings

- The format for a retest marking is: Month—Facility—Year—Plus Rating— Star Stamp.
- The + symbol (Plus Rating) indicates that the cylinder qualifies for 10% overfill.
- The . symbol (Star Stamp) indicates that the cylinder meets the requirements for 10-year retest.

#### 7. Cylinder Manufacturer's Inspection Marking

## Shipment of Gaseous Argon

All shipments of compressed argon must comply with DOT regulations. This applies to motor freight, rail, air, and water shipments. For air shipments all packages must not only comply with DOT regulations but also comply with International Air Transport Association/International Civil Air Organization (IATA/ICAO) Dangerous Goods regulations. Water vessel shipments must also be prepared in accordance with the International Maritime Organization (IMO) regulations. All packaging used to transport argon must be either "UN/DOT Specification" or "UN/DOT Authorized" and in proper condition for transport. DOT Code of Federal Regulations, Title 49, also specifies the following labeling and identification requirements:

DOT Shipping Name: Argon, Compressed

DOT Hazard Class: 2.2

DOT Shipping Label: Nonflammable Gas

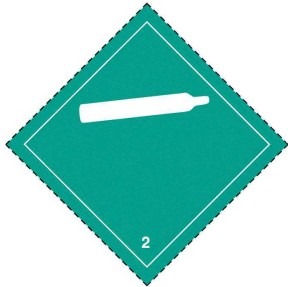

Identification Number: UN1006

## Safety Considerations

Asphyxiation and the high pressure of the gas in containers and systems are hazards associated with argon.

## Buildings

Provide adequate ventilation where Argon is being used, and test the atmosphere in confined work areas for oxygen content. A 19.5% oxygen concentration in the air is the minimum recommended for working without special breathing equipment.

## Personal Protective Equipment (PPE)

Personnel must be thoroughly familiar with properties and safety considerations before being allowed to handle argon and its associated equipment. Safety glasses, safety shoes, and leather work gloves are recommended when handling cylinders.

Only trained and certified emergency responders should respond to emergency situations. Clothing which is fire-resistant in air may be readily ignitable in oxygen-enriched atmospheres

## First Aid

First aid measures are not required for gas. If frostbite is suspected, flush eyes with cool water for 15 minutes and obtain immediate medical attention. For frostbite, immerse skin in lukewarm water. DO NOT USE HOT WATER. Obtain medical attention.

Self-contained breathing apparatus (SCBA) may be required to prevent asphyxiation of rescue personnel.

## Fire Fighting

Argon is nonflammable. A cylinder may vent rapidly or rupture violently from pressure when involved in a fire situation.

Although most cylinders are designed to vent contents when exposed to elevated temperatures, note that pressure in a container can build up due to heat and it may rupture if a pressure relief device should fail to function.

Firefighters should wear respiratory protection (SCBA) and full turnout or Bunker gear. Continue to cool fire-exposed containers until well after flames are extinguished.

## Handling and Storage

Argon is noncorrosive and may be used with all common structural materials. Use only in well-ventilated areas. Use local exhaust in combination with general ventilation as necessary to prevent accumulation of high concentrations and maintain air oxygen level at or above 19.5%.

Do not allow the temperature where cylinders are stored to exceed 125°F (52°C). Cylinders should be stored upright and firmly secured to prevent falling or being knocked over. Use a "first in-first out" inventory system to prevent full cylinders being stored for excessive periods of time.

Valve protection caps must remain in place unless container is secured with valve protection outlet piped to use point.

Do not drag, slide or roll cylinders. Use a suitable hand truck for cylinder movement.

Use a pressure reducing regulator when connecting cylinder to lower pressure piping or systems.

Do not heat cylinder by any means to increase the discharge rate of product from the cylinder. Use a check valve or trap in the discharge line to prevent hazardous back flow into the cylinder.

Protect cylinders from physical damage. Do not insert any object (i.e.: screwdriver) into valve cap openings as this can damage the valve causing leakage.

Never carry a compressed gas cylinder or a container of a gas in cryogenic liquid form in an enclosed space such as a car trunk, van or station wagon. A leak can result in a fire, explosion, asphyxiation or a toxic exposure.

For additional recommendations, consult Compressed Gas Association Pamphlets P-1, G-10.1, P-8.1, P-8.2, P-9, P-16, P-18, and Safety Bulletin SB-2.

## Emergency Response System

### Product Safety Information

- Call: 1-800-424-9300 (Continental U.S. and Puerto Rico)
- Call: 1-703-527-3887 (other locations)
- 24 hours a day, 7 days a week

For assistance involving Linde, Inc. products

For MSDS, Product Safety Assessment, and Product Safety Information,  
[www.linde.com](http://www.linde.com)

### Information Sources

- [www.us.lindegas.com](http://www.us.lindegas.com)
- Compressed Gas Association (CGA)  
[www.cganet.com](http://www.cganet.com)

### For More Information

Linde,  
575 Mountain Ave  
Murray Hill, NJ 07974-2082

***The accuracy or completeness of all statements, technical information and recommendations contained herein is not guaranteed and no warranty of any kind is made in respect thereto. Such statements and information are given for general use only and should not be solely relied upon by the recipient when establishing appropriate procedures for his or her own operation.***